

## Application:

Acceleration measurement for weighing objects in motion:

- Dynamic weight recording built into tipping units on refuse collection vehicles
- Weighing in robot arms etc.

## Features:

- Optimised accelerometer for weighing objects in motion (physically correct compensation of acceleration and tilt)
- Extremely robust housing
- Compact physical dimensions
- Overload capacity
- Integrated calibration memory
- High precision
- Frequency output signal

## Measuring principle:

The sensor is essentially a silicon differential capacitor, in which the deflection of the middle plate (seismic mass) is measured. The suspension of the capacitor plate ensures a pure vectorial measurement of the forces.

The signal is then converted electronically, so as to give an acceleration output in the form of a 5V TTL frequency signal.

The temperature is also measured in the sensor, allowing a computed temperature correction of both zero and gain.



Calibration data are stored in an integrated EEPROM memory.

## Description:

The BB accelerometer was developed specifically for dynamic weighing, a DIGI SENS speciality. Thanks to its small size and robust stainless-steel housing, it can be mounted near the centre of gravity of the object to be weighed, so as to measure its acceleration exactly.

When connected to a DIGI SENS „TARGO“ weighing computer, the weight of a load can be determined, even if this never comes to rest.

The specifications of the BB accelerometer are fully suited to this task. It has also been correspondingly officially tested, so that it can form part of a certified dynamic weighing system.

## Signal processing:

The data specific to the load cell are stored in a built-in memory. As a result, no calibration whatsoever is required either at commissioning or when changing a load cell.

A 5V TTL signal is available at the output. The DIGI SENS „TARGO“ computer is to be recommended for signal processing, it is designed for eight load cells and the data from the different cells can be combined in real-time.

## Technical Data

<b>Measuring Ranges</b> Acceleration 0.3...7.7g (2.94m/s <sup>2</sup> ....16.7m <sup>2</sup> ) Frequency range 0....30Hz	<b>Temperature drift</b> Zero 0.01% / 10k Sensitivity 0.01% / 10k	<b>Temperature range</b> Calibration -10...+40°C Service -30...+70°C
<b>Resolution</b> Acceleration 0.001g	<b>Warming-up time</b> For maximum error 0.03% < 5 Min	<b>Weight</b> BB 0.49kg
<b>Measurement uncertainty</b> Total error <0.03% Reproducibility <0.001g	<b>Power Supply</b> Voltage 5V DC ±0.2V Max. current consumption <20mA	<b>EMC</b> Corresponding to 95/94 EC, ISO7637-2, ISO11452-5, EN61000-4-2, EW61000-4-3, Grange CCG 001/A
<b>Overload capability</b> Without permanent damage 2000g	<b>Output signal</b> Frequency range 8....19kHz Sensitivity 5kHz/g Amplitude 5V TTL	Mark of conformity CE, e

## Dimensional drawing

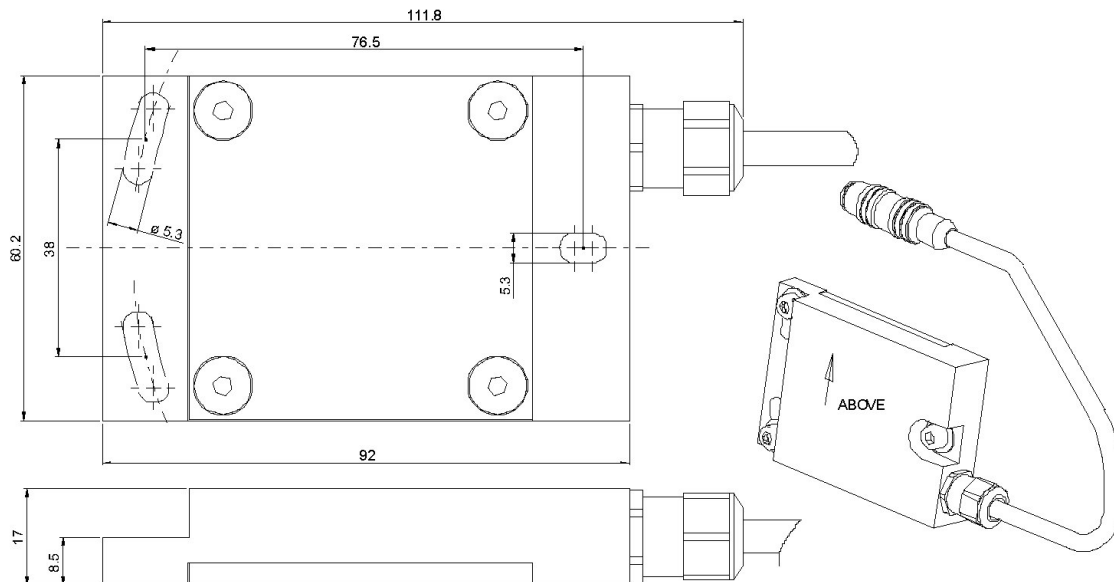

**DIGI SENS AG**

Digital Sensor Technology  
 Freiburgstrasse 65  
 CH – 3280 Murten  
 Switzerland

Tel. : +41 (0)26 672 98 76  
 Fax : +41 (0)26 672 98 79  
[sales@digisens.ch](mailto:sales@digisens.ch)  
<http://www.digisens.ch>

